

SPECIFICATIONS

Electrical Ratings	100mA @ 30VDC
Electrical Life	100,000 cycles typical
Contact Resistance	< 50 mΩ initial
Actuation Force	150 +/- 80gF 260 +/- 30gF
Actuator Travel	1.0 mm to lock 1.7 mm full travel
Dielectric Strength	1000Vrms min
Insulation Resistance	> 100MΩ min
Operating Temperature	-40°C to 85°C
Storage Temperature	-40°C to 85°C



MATERIALS ←RoHS COMPLIANT

Actuator	Acetal
Housing	PBT
Cover	PBT
Latching Pin	Stainless Steel
Spring	Stainless Steel
Contacts	Phosphor Bronze, Silver Plated
Terminals	Brass, Silver Plated

ORDERING INFORMATION

1. Series:	LP2284	F150	N
	LP2284		
2. Actuation Force:			
	F150 = 150gF		
	F260 = 260gF		
3. Latching:			
	N = Non-latching		
	L = Latching		

DIMENSIONS

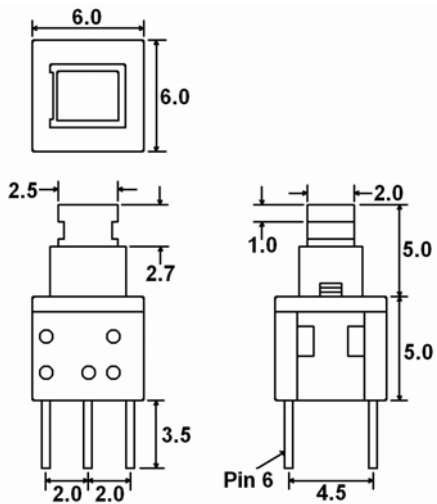

SCHEMATIC & PC LAYOUT

